

FLEXIFLOAT™ FIELD ASSEMBLY GUIDE

 **WARNING** READ CONTENTS CAREFULLY PRIOR TO USE



FLEXIFLOAT™

This Field Assembly Guide is intended to give users a basic understanding on how to assemble Flexifloat units. It is important that you read this guide carefully prior to use. If there is anything in this Guide that is not clear or you do not understand, immediately contact Robishaw Engineering, Inc. (REI). As the recipient of this Guide, it is your responsibility to ensure that it is provided to any person assembling, disassembling, using, maintaining or repairing this equipment.

This is only a guide and cannot anticipate every possible circumstance that might involve a potential hazard. You must satisfy yourself that the application and operating conditions are safe for you and others. Contact REI or other qualified professional prior to use. REI offers its engineering services free of charge to all Flexifloat users.

 **WARNING**

The use of Flexifloat equipment requires competent personnel and the application of engineering principles. **The improper use, operation, modification, maintenance or repair of Flexifloat equipment can be dangerous and result in property damage, injury or death.** Contact Robishaw Engineering, Inc. (REI) or other qualified professional prior to use. REI offers its engineering services free of charge to all Flexifloat users. Equipment used on or with Flexifloat barges must have the manufacturer's approval for use in marine applications.

Accidents involving the use, maintenance and repair of Flexifloat equipment are often caused by failure to observe basic safety rules or precautions. The majority of accidents can be avoided by recognizing potentially hazardous situations and observing basic safety rules and procedures. **Flexifloat users must always be aware of potential hazards and possess the necessary training, skills and tools to safely operate Flexifloat equipment. Failure to do so could result in injury or death.**

REI cannot anticipate every possible circumstance that might involve a potential hazard. If REI does not recommend or is not consulted, you must satisfy yourself that the application and operating conditions are safe for you and others. You should also make certain that the product will not be damaged or made unsafe by the use, operation, modification, maintenance or repair procedure you choose.

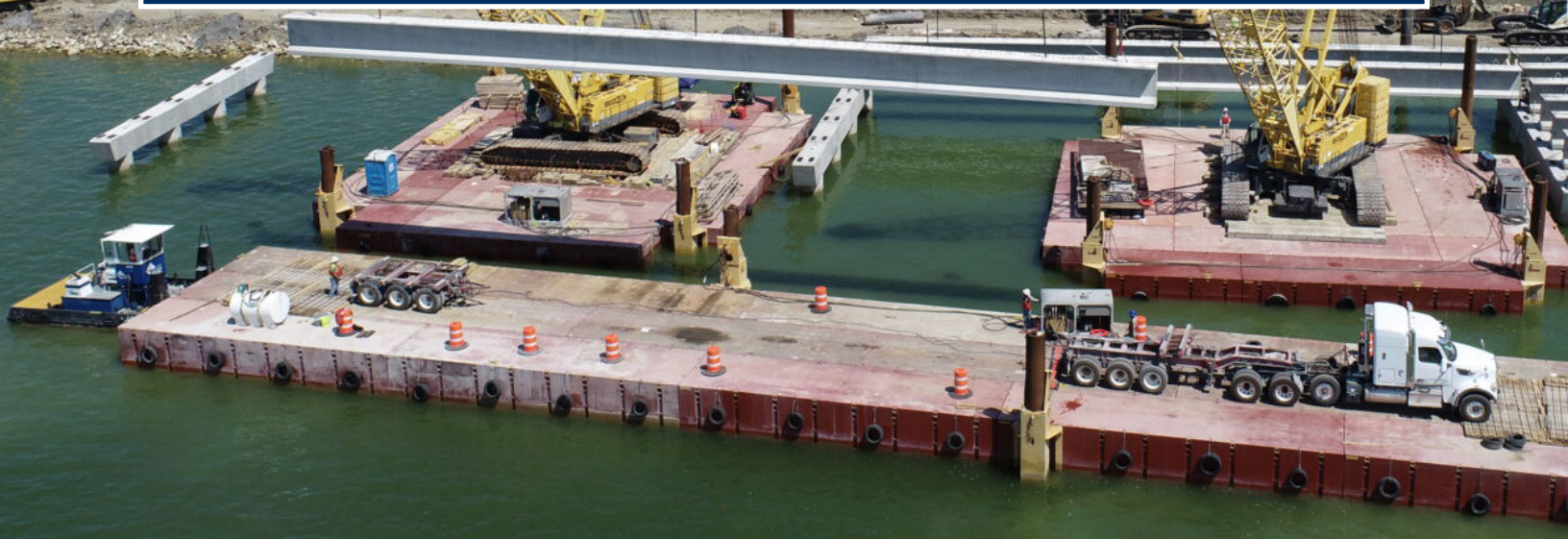

INSTALLATION & ASSEMBLY

Flexifloat modules are specifically designed for easy handling and rapid, in-water assembly. Most installations can be completed within one or two normal workdays. The primary tools needed for assembly are sledge hammers, pry bars, and short lengths of rope for hand lines. Certain modules or attachments may require additional slings or other standard lifting hardware, typically available on most jobsites. See attached Suggested Tools list.

Due to the orientation of the male and female Flexilocks, individual Flexifloat modules cannot be inserted into a “corner“, bounded by two adjacent units. The modules are usually first assembled into rows, or “strings“, then connected to a second, third or fourth row until the entire configuration is complete. Ancillary attachments, such as Loading Ramps and Spud systems, should be added after all Flexifloat units have been assembled.



Keep hands and feet away from locks when they are in the raised position!



Never assemble or disassemble Flexifloat modules under loaded conditions!

CUSTOMER SERVICE

Robishaw Engineering, Inc. is the sole designer and manufacturer of Flexifloat Construction Systems. For over 65 years of operations we have dedicated ourselves to providing not only superior products, but in-depth technical support and complimentary engineering services.

We offer comprehensive project analysis, barge design, and, when necessary, on-site consultation to assist users in the application of Flexifloat technology. Working closely with the customer, we develop and analyze information as to the scope of work to be performed, site conditions, access, and environmental restrictions as well as the type, weight, and layout of the equipment for the project.

SUGGESTED TOOLS

The following tools and equipment are normally required for the loading/unloading and assembly of Flexifloat equipment:

Pry bars, 5' Length	2 ea.
Sledge hammers, 10 to 12 lbs.	2 ea.
¾" manila, nylon, or poly rope for hand lines	300 ft.
1½ to 2-ton cable pull ratchets ("Come-a-longs")	3 ea.
Single-leg wire rope sling with appropriate hook or shackle into the FlexiDecks. Select wire size according to the following unit weights below:	1 ea.

Equipment Series	Maximum Weight	*Minimum Crane Capacity for Assembly
H-50	14,500 lbs.	35-ton
S-50	27,000 lbs.	50-ton
S-70	33,000 lbs.	80-ton

**Crane selection is dependent upon several factors including hook load weight, dimensions, required reach (radius), site conditions, and rigging. Appropriate crane and rigging selection is the responsibility of the user.*

ADDITIONAL TOOLS FOR SPUDS AND SPUDWELLS

One two-leg sling with appropriate hooks or shackles for lifting spud pipe sections weighing up to 12,000 lbs. (60-foot-long x 24" diameter spuds). A 25-ton capacity 2" dia. lifting bale is located at the top of the spud. Please note, non-standard spuds may weigh more.



Always ensure the load does not exceed the sling's maximum capacity. Failure to comply can lead to property damage, injury, or death.

IMPORTANT NOTICES

All Flexifloat female locks have a 1/2" bolt, friction plate, and nut located approximately 12" below each upper female casting. This bolt is used to adjust the friction force that enables the locking bar to remain in the raised position during assembly operations. The proper force was set at the factory. Field adjustment should not be necessary for the initial barge installation.

A 3/4" socket with back-up wrench can be used to loosen or tighten the friction plate as needed.



WARNING

When the locking bar is in the raised position, never use a female lock connection as a toe or hand hold for climbing onto a float or to pull floats together by grabbing the top portion of the locking bar. Any inadvertent downward force could cause the locking bar to fall resulting in severe injury to fingers and hands.



LOADING AND UNLOADING EQUIPMENT



Flexifloat barge sections and attachments are typically delivered to the jobsite using conventional tractor trailers.

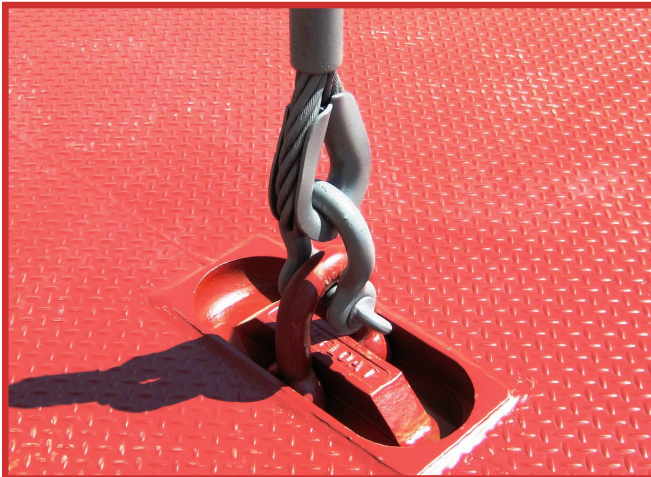

Flotation units have a single 25-ton capacity 1-3/4" recessed lift shackle located on the deck at the center of balance for rapid loading and unloading of the equipment.



Taglines (long ropes) should be used when lifting the barge sections with a crane. Lines attached to one or two points will help stabilize the load and prevent unwanted rotation that may cause a collision with other equipment or the crane itself. This also provides a safe working distance between ground personnel and the load (never stand under the load). Ropes may be fastened through the rope thimbles (5-ton capacity 3" dia. tube turns) that are located around the perimeter of each barge section.

LOCK OPERATION

Step 01: FlexiFloat Locking System

Flexifloat barge sections and attachments are typically delivered to the jobsite using conventional tractor trailers.

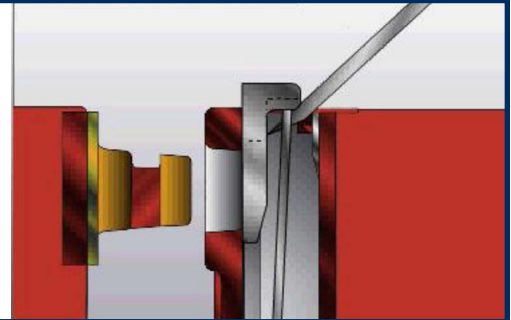

Step 02: FlexiFloat Locking System

Insert pry bar into female lock behind the spring bar and raise locking bar upwards.

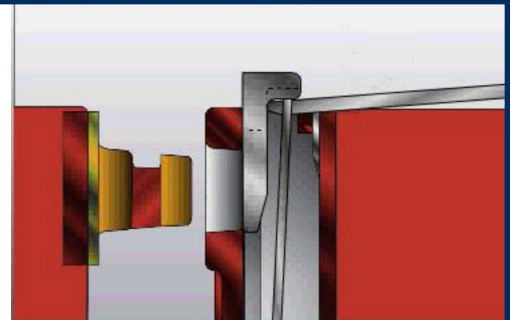

Step 03: FlexiFloat Locking System

Turn pry bar over and push it through the opening in the upper locking bar casting.

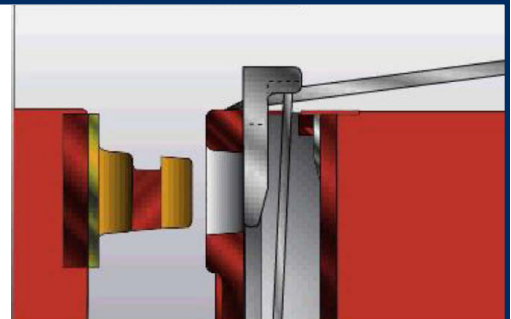

Step 04: FlexiFloat Locking System

Lift pry bar and continue raising locking bar until the opening in the female lock casting is completely clear and the locking bar stops.

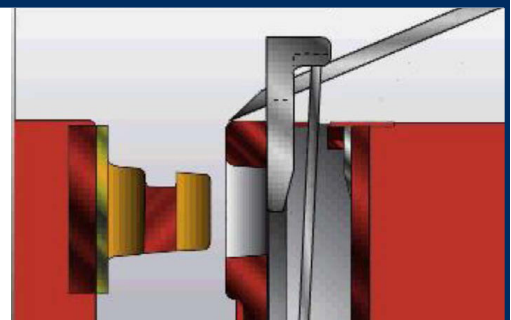

LOCK OPERATION

Step 05: FlexiFloat Locking System

Repeat Steps 1 through 4 for all connectors along the row. Be sure all locking bars are completely raised; otherwise the connection cannot be completed.

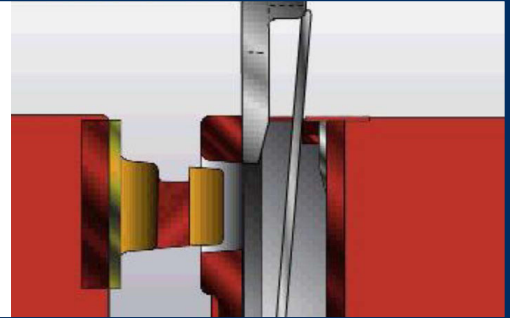

Step 06: FlexiFloat Locking System

Drift the Flexifloats together, using hand lines until the male pin enters the female lock casting.

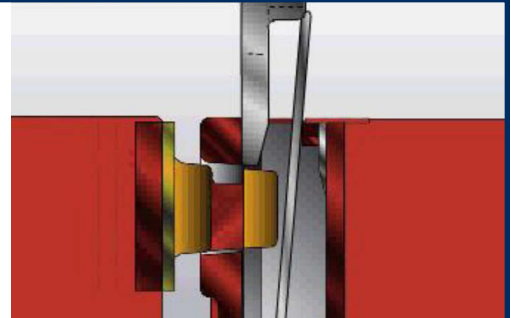

Step 07: FlexiFloat Locking System

Continue to pull the adjoining Flexifloat rows together until the shoulder of the male pin is in close proximity to the female lock casting. All upper and lower lock connections along the entire row must be in this position before attempting further lock operations.

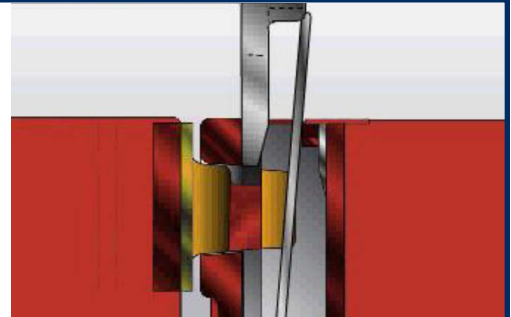

LOCK OPERATION NOTES



NOTE:

Barges can be pulled together by utilizing rope and the rope thimbles (5-ton capacity 3" dia. tube turns) located along the perimeter of the deck.



NOTE:

The use of multiple hand lines and/or small come-a-long installed across the deck of the two rows may be necessary to overcome friction forces. Check bottom locks are also properly engaged by inspecting the vertical gap between the Flexifloats.



NOTE:

Under certain conditions, it may be helpful to thread a small wire rope sling through a matching pair of the rope thimbles and gently lift with the crane. This will help close the upper lock gap and engage the lower lock faces.

LOCK OPERATION

Step 08: FlexiFloat Locking System

Begin driving the locking bar starting at the first connector location on one end of the row.

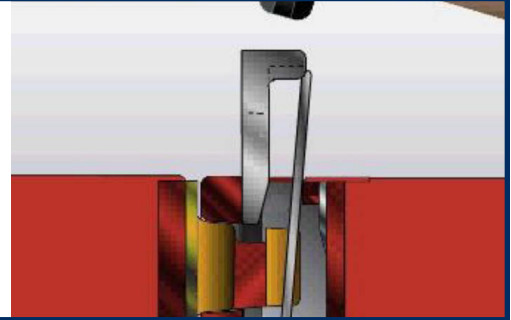

Step 09: FlexiFloat Locking System

Continue driving the locking bar. If driving becomes difficult or a "metal-on-metal" sound is heard; stop, raise the locking bar, and reinspect the vertical gap to ensure both the top and bottom male pins are being engaged, then continue driving.

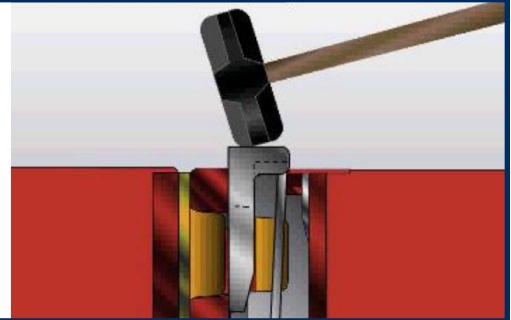

Step 10: FlexiFloat Locking System

Drive locking bar until the spring bar secures in place under the two protrusions at the back of the female lock.

Repeat Steps 8, 9, 10 in sequence (like closing a zipper), along the entire length of the row.

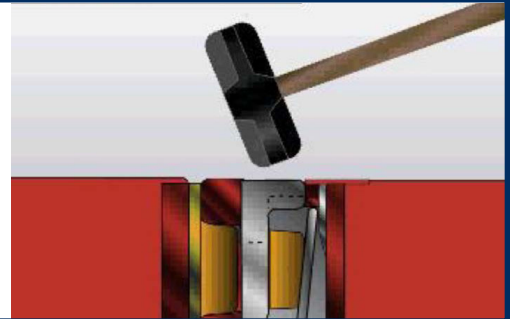

LOCK OPERATION SUMMARY

1: Use pry bar to raise locks.



2: Raise all locks on connection row.



3: Use rope to pull floats together, inserting male pin into female lock casting.



4: Use sledgehammer to drive locks down.



5: Check that floats are securely connected by making sure all locking bars are down and flush with deck.



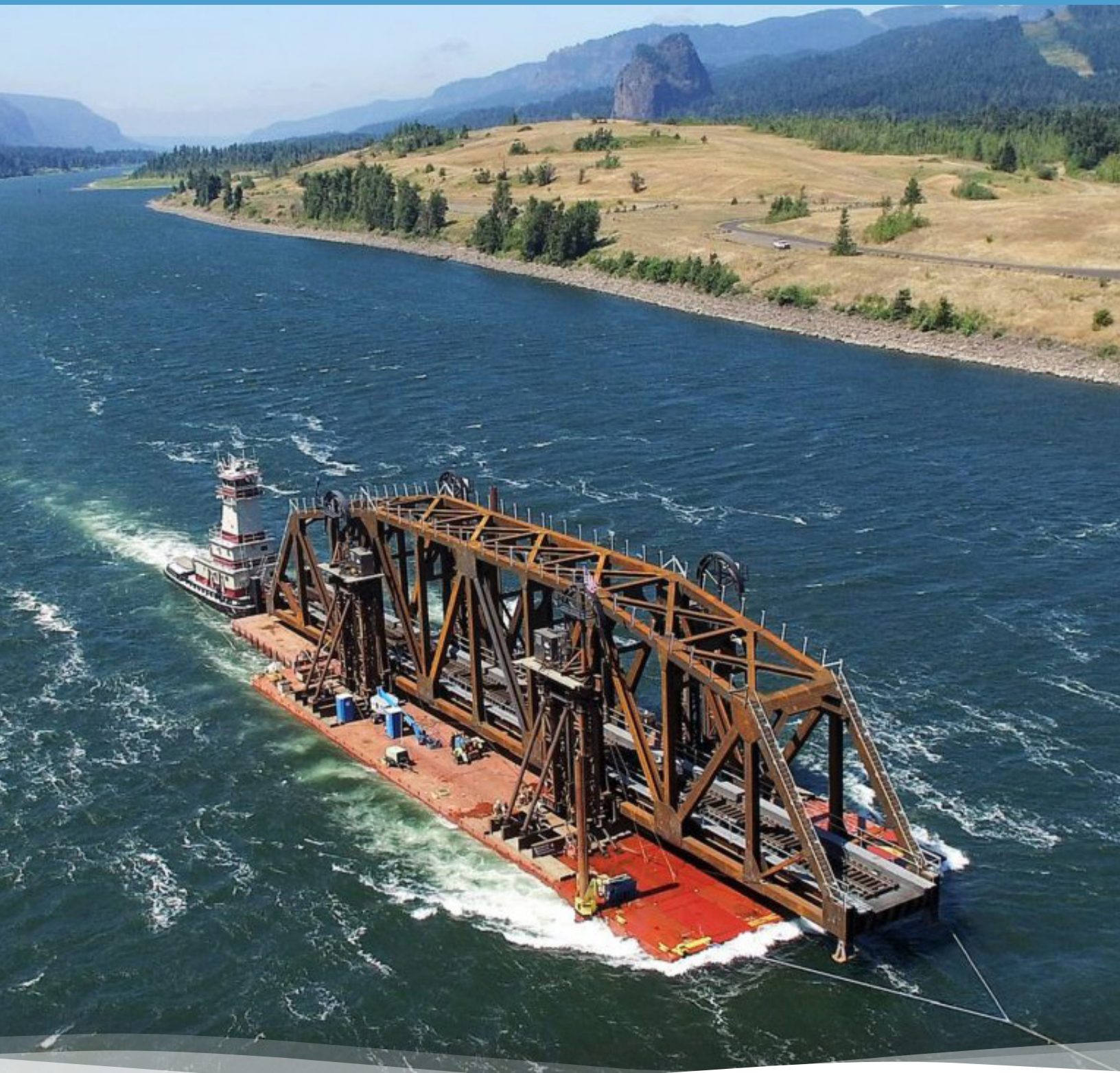

FLEXIFLOAT™

Robishaw Engineering, Inc.
Houston, Tx 77279-9246 | P.O. Box 79246
10106 Mathewson Lane, Houston, TX 77043
800.877.1706 | info@flexifloat.com